

# find+follow Purifier Cool

## User manual

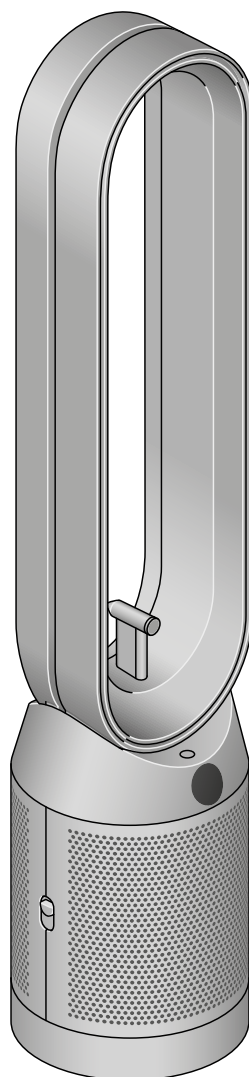

TP14  
438N JN.00000 PN.000000-00-00  
00.00.00 VERSION NO.01

---

### Contents

Getting started  
Connecting to the MyDyson™ app  
Connecting to your smart home  
Power and continuous monitoring  
Information menu  
Auto mode  
Airflow speed and direction  
Oscillation  
Sleep mode and Sleep timer  
Find+Follow™ air projection

Guidance on ensuring the best performance of the Find+Follow™ purifier  
Positioning your machine  
Activating Find+Follow™ air projection  
Find+Follow™ intelligence  
AI vision system field of view  
Changing your HEPA+K-Carbon filter  
Resetting your HEPA+K-Carbon filter life  
Looking after your machine

# Getting started

Use both hands to lift your machine out of the box, by its base. Do not lift out by the loop amplifier.

Your machine comes with a HEPA+K-Carbon filter.

Remove all protective packaging, including around the plug and cable. Plug in and press the 'Standby' on/off button on your Dyson air purifier to start/stop your machine. It will continue to monitor the air quality.

Place the remote control on top of the machine with the buttons facing down.

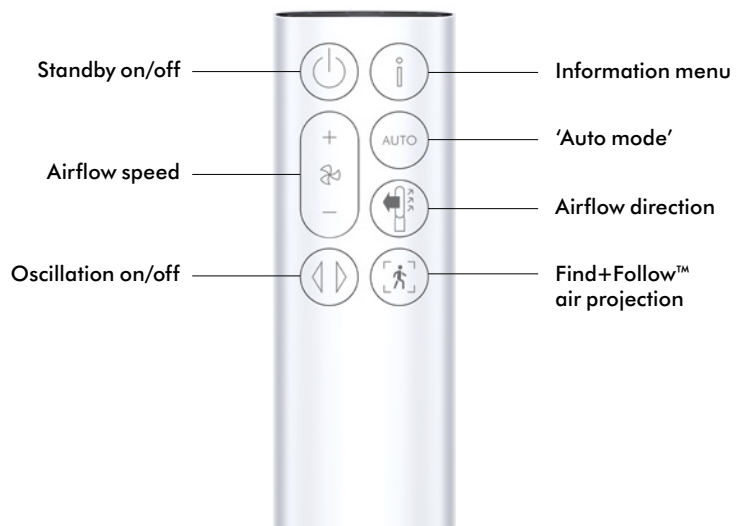
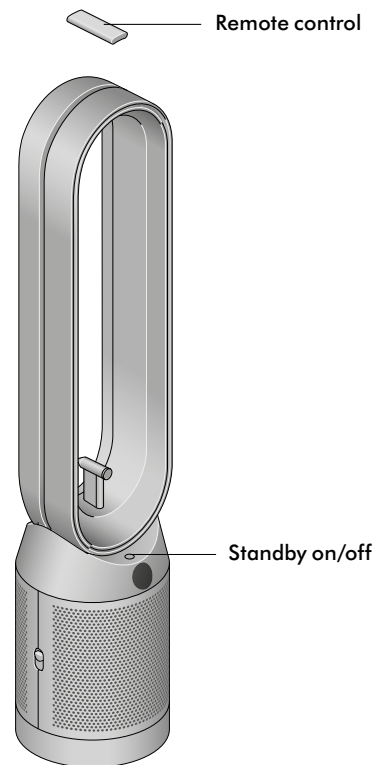

# Connecting to the MyDyson™ app

Take full control with the MyDyson™ app to:

- Access step-by-step setup and support.
- Control how and when your Dyson purifier operates.
- Monitor air quality with visual updates and automatically keep up to date with the latest software updates.

Download the MyDyson™ app from the App Store or Google Play.

Open the app and follow the on-screen instructions to create a new account.



Apple and the Apple logo are trademarks of Apple Inc., registered in the U.S. and other countries. App Store is a service mark of Apple Inc., registered in the U.S. and other countries. Google Play and the Google Play logo are trademarks of Google Inc.



The Android robot is reproduced or modified from work created and shared by Google and used according to terms described in the Creative Commons 3.0 Attribution License.



---

## Connecting to your smart home

### Using Amazon Alexa

Ask Alexa to enable the Dyson skill to control your Dyson purifier. Set a routine that automates how your machine works with other devices in your home.

Amazon, Alexa, Amazon Echo and all related logos are trademarks of Amazon.com, Inc. or its affiliates.



### Using Google Assistant

Control all of your connected purifiers with Google, or set a routine to automate how your machine works with other devices in your home. Just say "Hey Google" to get started.

Google Play, the Google Play logo and Google Assistant are trademarks of Google Inc.



### Using Siri

Connect your Dyson machines to Siri Shortcuts and you'll be able to control them with your voice, on your Apple device.

Apple, the Apple logo and Siri are trademarks of Apple Inc. App Store is a service mark of Apple Inc.



# Power and continuous monitoring

## **Standby on/off**

Press the 'Standby' on/off button on your Dyson purifier or remote control to stop your machine. It will continue to monitor the air quality.

## **Continuous monitoring**

Continuous monitoring is turned off by default. Once turned on, it will always be active until you turn it off again.

With continuous monitoring turned on, your Dyson purifier will gather air quality, temperature and humidity information. This is displayed on the LCD screen and in the MyDyson™ app.

Press and hold the 'Auto mode' button on the remote control for five seconds to turn it on. The LCD screen will indicate when continuous monitoring is on or off.

## **Wi-Fi connectivity**

Wi-Fi is on by default. To turn the Wi-Fi on or off, press and hold the 'Standby' on/off button on your machine for five seconds.

# Information menu

The remote control uses infrared to communicate with your machine.

Press the 'Information' button to scroll through the information being monitored by your Dyson purifier.

Information about air quality, temperature, humidity and filter levels is shown on the LCD screen.

When a particular type of pollutant causes air quality to decrease, a symbol for the pollutant will show on the LCD screen.



## Indoor air quality

Monitor the current air quality with a graph showing the last 12 seconds of data.



## Particulate matter (PM2.5)

Microscopic particles up to 2.5 microns in size, suspended in the air we breathe. These include smoke, bacteria and allergens.



## Particulate matter (PM10)

Larger microscopic particles up to 10 microns in size, suspended in the air we breathe. These include dust, mould and pollen.



## Volatile organic compounds (VOCs)

VOCs are typically odours that may be potentially harmful. These can be found in cleaning products, paints and furnishings.



## Nitrogen dioxide and other oxidising gases

These potentially harmful gases are released into the air by combustion. For example, burning gas when cooking and in vehicle exhaust emissions.



## Indoor temperature

Monitor the ambient temperature to help maintain a comfortable environment.



## Indoor humidity

The amount of water vapour in the air, shown as a percentage.



## Filters

The remaining filter life is shown on the LCD screen and will indicate when your filters need replacing.



## Wi-Fi

The current status of connection to the Wi-Fi network.



# Auto mode

Set your Dyson purifier to 'Auto mode' and the on-board sensors will intelligently adjust the settings of the machine according to the air quality.

**Air quality:** your machine will pause when the target air quality has been reached, switching on again when the air quality levels drop.

**Airflow speed:** the airflow speed will increase until the target air quality and temperature have been reached.



# Airflow speed and direction

Press the 'Airflow speed' button to increase and decrease the airflow speed.

Press the 'Airflow direction' button to change the direction of airflow from front to back.

Change the airflow direction for your personal comfort.

Select the 'Airflow direction' button to 'Fan mode' for airflow from the front for purifying and cooling.

Switching to 'Diffuse mode' will disable Find+Follow™ air projection.



# Oscillation

Press the 'Oscillation' button to circulate the air around the room and scroll through the oscillation settings from 0° to 350°.

Customise your oscillation setting in the MyDyson™ app.



# Sleep mode and Sleep timer

In 'Sleep mode', your Dyson purifier will continue to monitor and respond to changes in air quality, but only using its quietest settings – and with its LCD screen dimmed.

When using 'Sleep timer', your Dyson purifier will turn off automatically after the selected amount of time.

You can set both 'Sleep mode' and 'Sleep timer' using the MyDyson™ app.

# Find+Follow™ air projection

Find+Follow™ air projection will be turned off by default when first using the machine.

Dyson's Find+Follow™ AI vision system never identifies anyone and only detects presence. Images are processed instantly within the machine, deleted and never leave the device.

---

## Guidance on ensuring the best performance of the Find+Follow™ purifier

To maximise the performance of the Find+Follow™ AI vision system, please follow these recommendations:

- 1. Position your fan so the AI vision system has a clear, unobstructed view** of the area you want to monitor. Ensure the fan is positioned at least 0.5 metres away from objects, or that nearby furniture is low enough to allow the vision system to have line-of-sight of people in the detection area.
- 2. Ensure the area is sufficiently lit** by using natural daylight or artificial lighting to keep the monitored area well-lit. Performance may be reduced in low-light conditions.
- 3. Avoid facing the fan directly towards strong light sources**, such as large windows with direct sunlight. This can cause unwanted glare or backlighting, potentially reducing the performance.
- 4. To ensure tracking works as intended**, please rotate your machine so that the Dyson logo is pointing towards where you will use the machine the most.
- 5. Keep your fan clean and free of dust**, ensuring maximum image clarity for the AI vision system.

---

## Positioning your machine

Position your machine on a level floor and at least 0.5m away from any obstructions.

Make sure nearby furniture is low enough to not obstruct the view of the AI vision system.

Ensure the area is sufficiently lit and avoid facing the AI vision system directly towards any strong light sources.

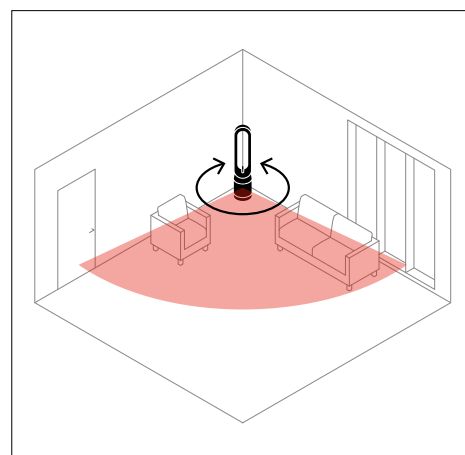

# Activating Find+Follow™ air projection

To activate Find+Follow™ air projection, press the 'Find+Follow™' button on the remote. The user must be in the line of sight of the AI vision system to ensure that presence is detected.



Once Find+Follow™ air projection is active and a user has been detected, the screen will show the icon pictured to the right.

Find+Follow™ air projection will intelligently detect the presence and movement of individuals within the room. As people enter or leave the AI vision system's field of view, the machine automatically adapts its oscillation range to ensure air is only delivered to areas where there are people in the room. When only one user is detected, the machine will follow just that one person.



If a user enters the room and is out of view of the AI vision system, a manual scan can be done by pressing the 'Find+Follow™' button on the remote.

The machine will oscillate to scan the room and detect users outside of the initial field of view. It then adapts the oscillation range to share between all individuals detected during the scan.



The animation pictured to the right will be displayed on the product screen while the product scans for other people in the room.

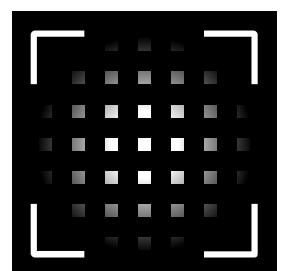

# Find+Follow™ intelligence

When Find+Follow™ intelligence is activated and no users are detected or everyone has left the room, the machine will enter a dormant state. While dormant, the fan will continue but the machine will remain stationary in its current position and wait for a user to be detected.

After one hour of being dormant, the machine will then enter 'Auto mode'. When the machine is in its dormant state, the screen will display the blinking icon in the top corner.



To turn off the Find+Follow™ feature and deactivate the AI vision system, either press and hold the 'Find+Follow™' button on the remote when the feature is active, or press the 'Find+Follow™' button while the machine is performing a manual scan. This will be confirmed by the Find+Follow™ off icon on the display.



# AI vision system field of view

## Field of view

If you are in the room and within the 100° field of view (FOV) of the machine (see the green area in the image to the right) when the Find+Follow™ feature is initiated, then you will be detected.

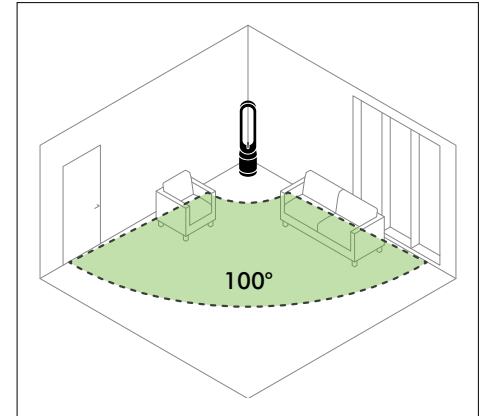

## Manual scan range

When the 'Find+Follow™' button is pressed again to initiate a scan (see the 'Activating Find+Follow™ air projection' section), the machine oscillates to look for users in the extended 220° scanning range (see the green area in the image to the right).

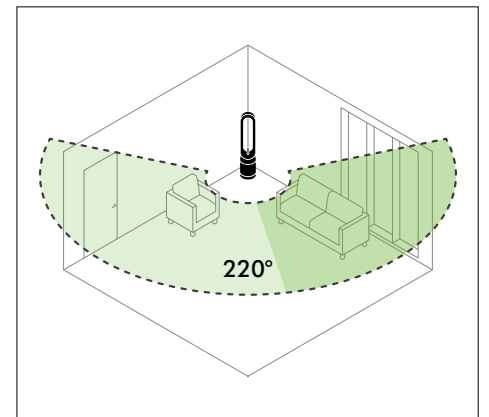

## Active tracking

When actively tracking, the machine can follow someone or oscillate between multiple users within the full 350° oscillation range (see the green area in the image to the right).

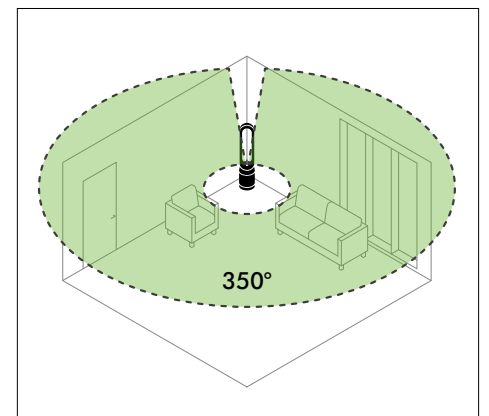

# Changing your HEPA+K-Carbon filter

Before changing your filter, switch off and unplug your Dyson Purifier.

The remaining filter life is displayed on the screen and will indicate when your non-washable filters need to be replaced.

Press the 'Information' button on your remote or check on the MyDyson™ app.

You'll need to reset the filter life on your machine.

## Dyson Find+Follow™ Purifier Cool

Your machine comes with a HEPA+K-Carbon filter.

To change your HEPA+K-Carbon filter, push down on the buttons either side of your machine to release the outer cover. Push down on the tabs to remove the filter.

Push the replacement filter into the outer cover and make sure the tabs click into place.

Put the outer covers into position on your machine and push firmly until they both click securely into position.

Plug in and switch on your machine, and reset your filter life.

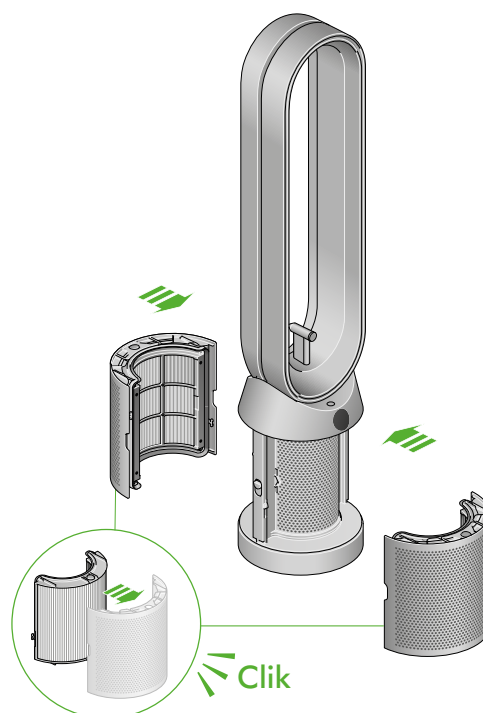

# Resetting your HEPA+K-Carbon filter life

It's important to reset your filter life after you have replaced your filter.

## Resetting your HEPA+K-Carbon filter life

Press and hold the 'Oscillation mode' button on your remote control.

The display on your machine will count down from five, the filter life will be reset and your machine will be ready to use.

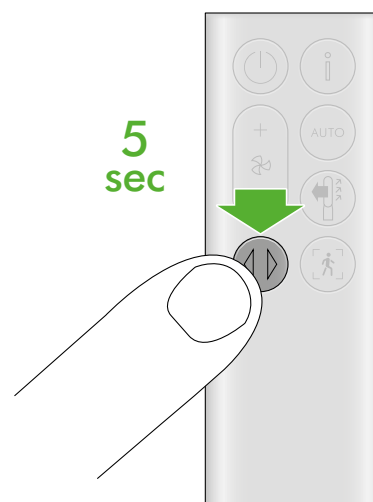

# Looking after your machine

To always get the best performance from your Dyson purifier, it's important to regularly clean it and check for blockages.

## **Cleaning your machine**

If your machine is dusty, wipe it with a damp, lint-free cloth.

Look for blockages in the air inlet holes on the filter and the small aperture inside the loop amplifier.

Use a soft brush to remove dust and debris.

Don't use detergents or polishes to clean your machine.

## **Error codes**

If your machine shows an error code, try turning it off and then on again.

If this doesn't clear the error code contact Dyson Customer Care.

For more information and support for your machine, go to the MyDyson™ app or visit online: [www.Dyson.co.uk/support](http://www.Dyson.co.uk/support)