

purifier cool PC2

De-NO_x

Purifier cool PC2 De-NO_x logo

User manual

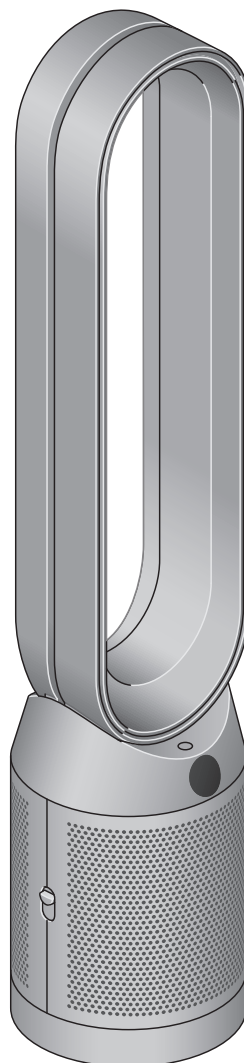

Front view of the Dyson Purifier Cool PC2 De-NO_x fan, showing the amplifier loop and mesh filter cover, screen below the loop amplifier and outer cover release button on the side.

Contents

Assembling your machine

Getting started

Connecting to the MyDyson™ app

Connecting to your smart home

Power and continuous monitoring

Information menu

Auto mode

Airflow speed and direction

Oscillation

Night mode and Sleep timer

Changing your HEPA+K-Carbon filters with a catalytic filter

Resetting your HEPA+K-Carbon filter life

Looking after your machine

Assembling your machine

Use both hands to lift your machine out of the box, by its base.

Do not lift out by the loop amplifier.

Assemble your machine with the filters that are supplied.

The air purifier fan with the filter covers open showing a HEPA plus K-carbon filter located in the filter covers and a catalytic filter. Arrows demonstrate that the catalytic filter is fitted directly to the base of the machine and the filter covers will need to be assembled onto the base of the machine.

Dyson Purifier Cool PC2 De-NOx

Your machine comes with a permanent catalytic filter and a HEPA+K-Carbon filter.

Push the catalytic filter into position on the machine.

Push the HEPA+K-Carbon filter into the outer cover and position on the base.

Push firmly until both outer covers click into place.

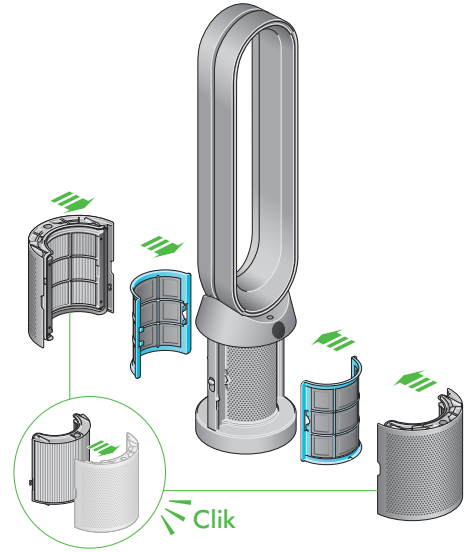

Getting started

Place the remote control on top of the machine with the buttons facing down.

Plug in and switch on.

An image of the air purifier fan with the remote placed on the top of the loop amplifier and the location of the standby on/off button on the top of the base of the machine.

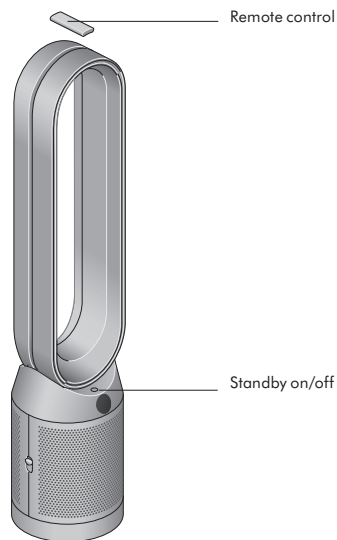

The layout of the remote control with two columns of buttons. On the top left-hand side is the standby button, then going downwards, the Airflow speed toggle up and down button, and the Oscillation button at the bottom. On the top right-hand side is the Information menu button, then going downwards, the Auto mode button, the Airflow direction button and the Night mode button at the bottom.

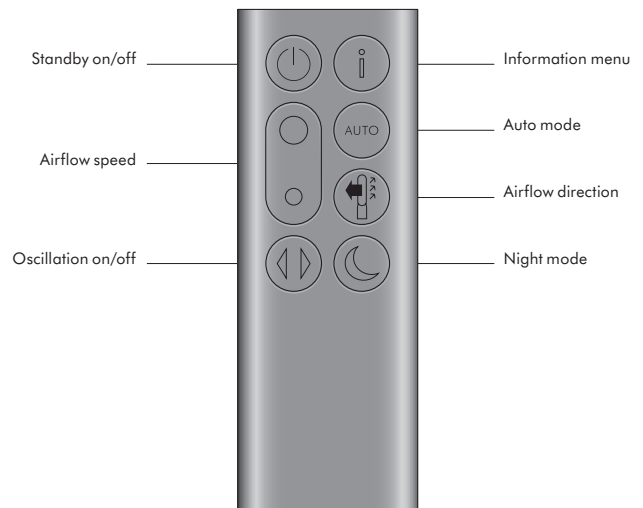

Connecting to the MyDyson™ app

Take full control with the MyDyson™ app and access step-by-step setup and support, control how and when your Dyson purifier operates, monitor air quality with visual updates and automatically keep up to date with the latest software updates.

Download the MyDyson™ app from the App Store or Google Play.

Open the app and follow the on-screen instructions to create a new account.



Apple and the Apple logo are trademarks of Apple Inc., registered in the U.S. and other countries. App Store is a service mark of Apple Inc., registered in the U.S. and other countries. Google Play and the Google Play logo are trademarks of Google Inc.



The Android robot is reproduced or modified from work created and shared by Google and used according to terms described in the Creative Commons 3.0 Attribution License.



Connecting to your smart home

Using Amazon Alexa

Ask Alexa to enable the Dyson skill, to control your Dyson purifier or purifier humidifier. And set a routine that automates how your machine works with other devices in your home.



Using Google Assistant

Control all of your connected purifiers with Google or set a routine to automate how your machine works with other devices in your home. Just say "Hey Google" to get started.



Using Siri

Connect your Dyson machines to Siri Shortcuts and you'll be able to control them with your voice, on your Apple device.



Power and continuous monitoring

Standby on/off

Press the Standby on/off button on your Dyson purifier or remote control to stop your machine. It will continue to monitor the air quality.

Continuous monitoring

Continuous monitoring is turned off by default. Once turned on, it will always be active until you turn it off again.

With continuous monitoring turned on, your Dyson purifier will gather air quality, temperature and humidity information, which is displayed on the LCD screen and in the MyDyson™ app.

Press and hold the Auto mode button on the remote control for five seconds to turn it on. The LCD screen will indicate when continuous monitoring is on or off.

Wi-Fi Connectivity

Wi-Fi is on by default. To turn the Wi-Fi on or off, press and hold the Standby on/off button on your machine for five seconds.

Information menu

Press this button to scroll through the information being monitored by your Dyson purifier.

Information about air quality, temperature, humidity and filter levels is shown on the LCD screen.

When a particular type of pollutant causes air quality to decrease, a symbol for the pollutant will show on the LCD screen.



The remote control with the information button on the top right.

Indoor air quality – 12 seconds

Monitor the current air quality with a graph showing the last 12 seconds of data.



Particulate matter (PM2.5)

Microscopic particles up to 2.5 microns in size, suspended in the air we breathe. These include smoke, bacteria and allergens.



Particulate matter (PM10)

Larger microscopic particles up to 10 microns in size, suspended in the air we breathe. These include dust, mould and pollen."



Volatile organic compounds

VOCs are typically odours that may be potentially harmful. These can be found in cleaning products, paints and furnishings.



Nitrogen dioxide and other oxidising gases

These potentially harmful gases are released into the air by combustion, for example, the burning gas when cooking and in vehicle exhaust emissions.



Indoor temperature

Monitor the ambient temperature to help maintain a comfortable environment.



Indoor humidity

The amount of water vapour in the air, shown as a percentage.



Filters

The remaining filter life is shown on the LCD screen and will indicate when your filters need replacing



Formaldehyde (HCHO)

A common indoor pollutant. It can be released for many years from furnishings, floorings and glue.



Wi-Fi

The current status of connection to the Wi-Fi network.



Auto mode

Set your Dyson purifying fan to Auto mode and the on-board sensors will intelligently adjust the settings of the machine according to the air quality.

Air quality: your machine will pause when the target air quality has been reached, switching on again when the air quality levels drop.

Airflow speed: the airflow speed will increase until the target air quality and temperature have been reached.

The remote control with the Auto mode button below the Information button on the right.



Airflow speed and direction

Press the Airflow speed button to increase and decrease the airflow speed.

Press the Airflow direction button to change the direction of airflow from front to back.

Change the airflow direction for your personal comfort.

Select the Airflow direction to Fan mode for airflow from the front for purifying and cooling.

The remote control with the Airflow speed toggle button on the left hand side, in the middle. The Airflow direction button is on the right below the Auto mode button.



Oscillation

Press the Oscillation button to circulate the air around the room and scroll through the oscillation settings from 0° to 350°.

Customise your oscillation setting in the MyDyson™ app.

The remote control with the oscillation button on the bottom left.



Night mode and Sleep timer

In Night mode, your Dyson purifier will continue to monitor and respond to changes in air quality, but only using its quietest settings – and with its LCD screen dimmed.

Press the Night mode and Sleep timer button to scroll through the timer options.

The remote control with the Night mode and sleep timer button on the bottom right.



Changing your HEPA+K-Carbon filters with a catalytic filter

Before changing your filter, switch off and unplug your Dyson purifier.

The remaining filter life is displayed on the screen and will indicate when your non-washable filters need replacing. Press the Information button on your remote or check on the MyDyson™ app.

You'll need to reset the filter life on your machine.

Dyson Purifier Cool PC2 De-NOx

Your machine comes with a permanent catalytic filter and a HEPA+K-Carbon filter.

You won't need to change your catalytic filter.

To change your HEPA+K-Carbon filter, push down on the buttons either side of your machine to release the outer cover. Push down on the tabs to remove the filter.

Push the replacement filter into the outer cover and make sure the tabs click into place.

Put the outer covers into position on your machine and push firmly until they both click securely into position.

Plug in and switch your machine, and reset your filter life.

The air purifier fan with the filter covers open showing a HEPA plus K-Carbon filter located in the filter covers. Arrows demonstrate that the filter is fitted directly to the base of the machine and the filter covers will need to be assembled onto the base of the machine.

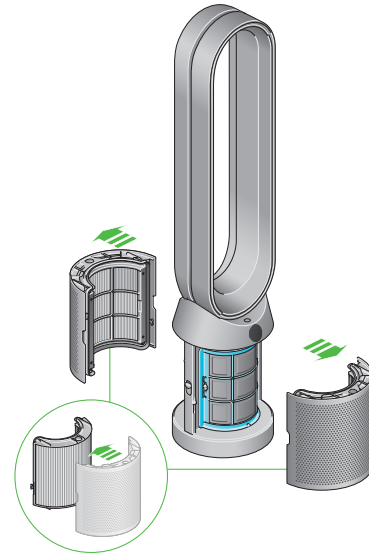

Resetting your HEPA+K-Carbon filter life

It's important to reset your filter life after you have replaced your filter.

Resetting your HEPA+K-Carbon filter life

Press and hold the Night mode button on your remote control.

The display on your machine will countdown from five, the filter life will be reset and your machine is ready to use.

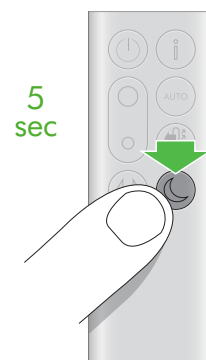

Pressing the Night mode and Sleep timer button on the bottom right of the remote control for 5 seconds.

Looking after your machine

To always get the best performance from your Dyson purifier, it's important to regularly clean it and check for blockages.

Cleaning your machine

If your machine is dusty, wipe with a damp lint-free cloth.

Look for blockages in the air inlet holes on the filter and the small aperture inside the loop amplifier.

Use a soft brush to remove dust and debris.

Don't use detergents or polishes to clean your machine.

Error codes

If your machine shows an error code, try turning it off and then on again.

If this doesn't clear the error code contact Dyson Customer Care.

For more information and support for your machine go to the MyDyson™ app or online:
www.dyson.co.th/en-TH/products/air-purifiers/purifier-cool-pc2-de-nox/owners